



Your Accessibility Partners

Telecab Planning Guide



Dec. 2005

Company intro

Savaria Concord Lifts is now the second largest accessibility company in North America. Savaria was founded in 1979, and has acquired Concord Elevator Inc. in July 2005.

Savaria Concord Lifts' mission is to provide products that facilitate mobility of all people with special needs, contributing to their well-being and quality of life.

Savaria Concord Lifts stands behind all its products, which meet safety standard requirements for various countries around the world. With the help of our network of over 600 distributors, our products are distributed in North America, South America, Europe, and Australia. In addition, we now have an exclusive dealer and partnership in Dubai, United Arab Emirates.

We manufactured over 4400 lifts and stairlifts in 2006 at the facility of Savaria. Our products contribute to a higher quality of life in homes and businesses by improving access.

It is a pleasure to introduce you to Savaria's complete line of accessibility products.

- V-1504 Vertical Platform Lift
- P.A.L Vertical Platform Lift
- Telecab Vanishing Residential Elevator
- Multilift Residential Acme Screw Drive Vertical Platform Lift
- ES-125 Stair Platform Lift
- Step-Saver™ Stairway Chairlift
- B.07 Stairway Chairlift (battery, 110VAC power, or commercial)
- Stairfriend™ Curved Stairway Chairlift
- Orion Lu/La Commercial Elevator
- Prolift Residential or Commercial Elevator
- Ultimo Residential or Commercial Elevator

We thank you for your support and interest in our company.

Cordially,



Marcel Bourassa, B.A.A.
President



Robert Berthiaume, P. Eng.
Executive V.P.

Definition of a Telecab

The Telecab, a residential two-stop elevator, maximizes living space and keeps construction to a minimum by eliminating the need for a hoistway. The Telecab's modern design harmonizes with any environment. It's an economical, attractive and dependable solution, allowing mobility-impaired people to move from one floor to another.

According to **A.S.M.E.** safety standard, an elevator is a hoisting and lowering mechanism, equipped with a car or platform, which moves on guide rails and serves two or more landings. The Telecab is covered by that definition, and is considered as a private residence elevator.

Please contact your local dealer for further details.

Table of contents

Company intro.....**Error! Bookmark not defined.**
 Definition of a Telecab 3

1- Technical analysis of the Telecab..... 5
 Specifications 5

2- Telecab residential elevator 6
 Anatomy of the lift 6
 Site construction details 7
 Rail reactions 7
 Support wall configuration (1)..... 7

3- Annex..... 8
 3.1- Traditional..... 8
 3.2- Premium..... 9
 3.3 Telecab Type I 10
 3.4 Telecab Type II 11
 3.5 Telecab Type III one door..... 12
 3.6 Telecab Type III two doors..... 13
 3.7 Telecab Type IV one door 14
 3.8 Telecab Type IV two doors..... 15

4- Architect specifications 16

1- Technical analysis of the Telecab

Specifications

Rated Load (capacity)	500 lb (227 kg)
Rated Speed	25 feet/min (0.07 m/s)
Tower	8 ft. modular guide rail for easy access on site Roller guide shoes
Platform	Non-skid platform surface
Cab	Three piece modular cab design ¼" (6 mm) Plexiglas windows Dimension 30"W x 46"L x 78"H (762 x 1,168 x 1,981 mm)
Levels Serviced	2 or 3 (Optional)
Operations	115 VAC relay logic operation(115 VAC up direction and 12 VDC down) Continuous pressure directional push buttons Keyed call / send stations
Max Travel	Up to 23' (7000mm)
Power Supply	110 VAC, 20 amps, 1 phase
Car Access	Enter/Exit same side or front/rear Time delay for automatic door lock system
Drive system	2:1 Roller chain hydraulic
Motor/Pump	110 VAC, 1.5 HP/Screw type
Electrical	Automatic battery recharging system (115 VAC) Low voltage controls
Finish	White electrostatic powder coat paint on all steel surfaces and vacuum-formed plastics.
Other	34" x 59" (864 x 1499 mm) minimum floor cutout 90" (2286 mm) minimum overhead at top landing Conforms to ASME A17.1

2- Telecab residential elevator

Savaria Telecab model is offered in several types of configurations & sizes.

Anatomy of the lift

Telecab consists of a tower, a cab, and floor plug system. Here is the general layout of the Telecab.

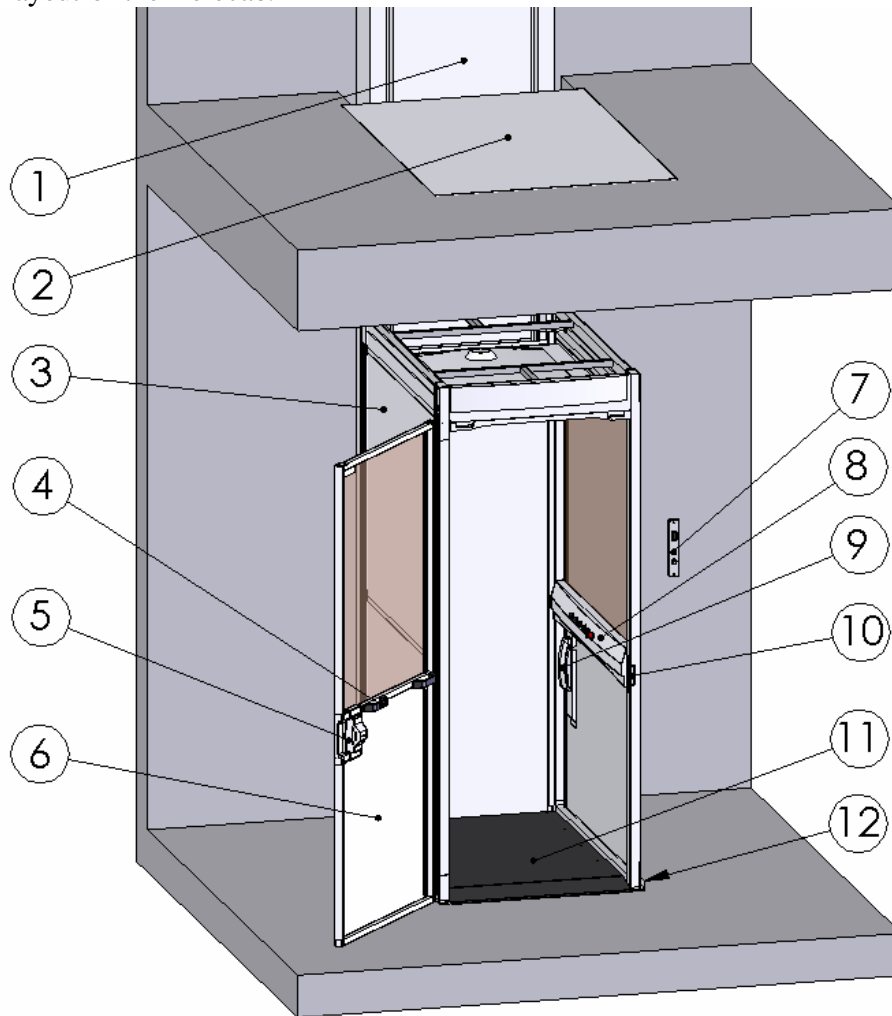

Shown here, type I or II cab configuration

Number	Description	Number	Description
1	Modular tower	7	Call/send station
2	Floor trap	8	Control operating panel (C.O.P.)
3	Cab	9	Emergency telephone
4	Door handles	10	Electro-mechanical door lock
5	Door latch	11	Non-skid beveled entry floor
6	Cab door	12	Safety underpan

Site construction details

Telecab needs a minimum of support to operate. In fact you will need a wall that can support 700 pounds (3114 N) of pull out force at any point.

Rail reactions

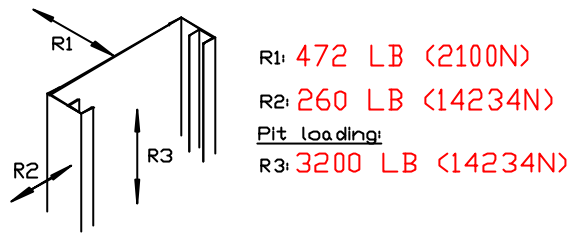

Support wall configuration (1)

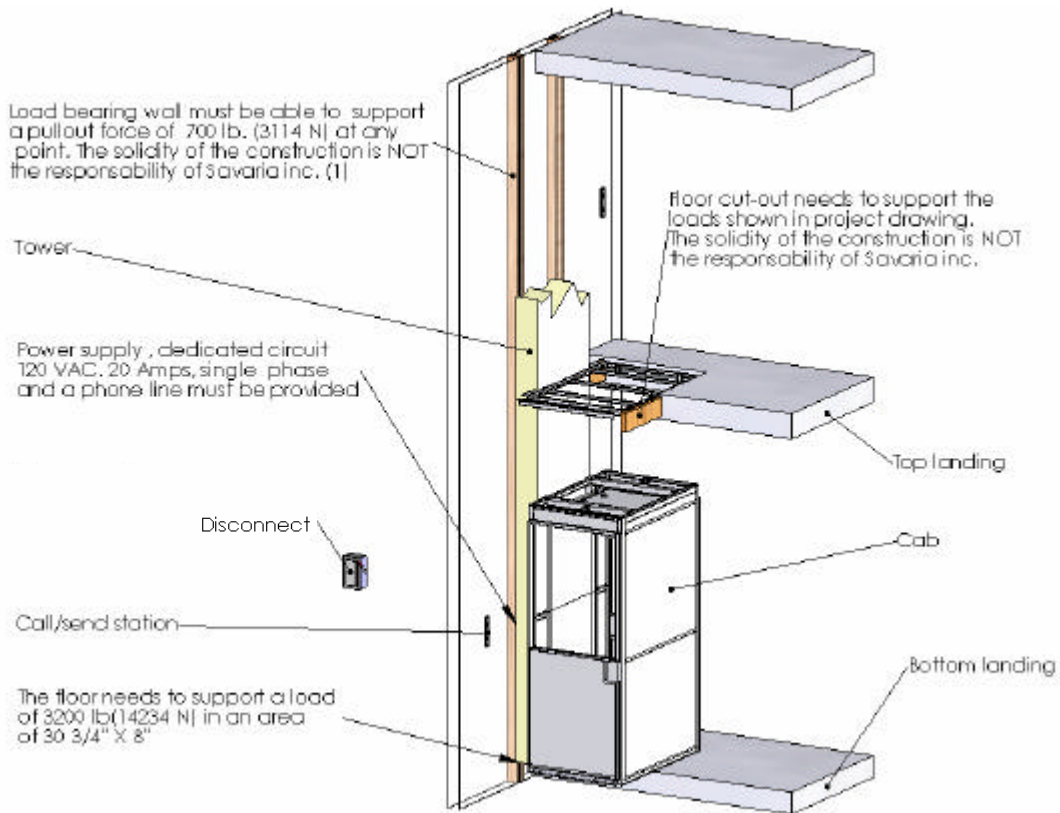
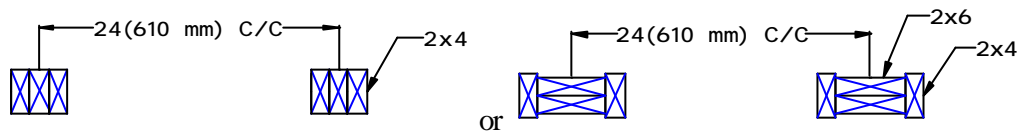

Shown here, type III or IV cab configuration

3.2- Premium

<p>DRAWING APPROVAL: THIS DRAWING REFLECTS OUR INTERPRETATION OF THE INFORMATION PROVIDED BY THE CLIENT FOR THE TELECAB SYSTEM. THE INFORMATION IS THE DEALER'S RESPONSIBILITY, AND IS THE BASIS FROM WHICH THE TELECAB ELEVATOR IS DESIGNED AND MANUFACTURED. PLEASE INDICATE THE REQUESTED ACTION BY CHECKING ONE OF THE FOLLOWING BOXES AND SIGNING BELOW TO AUTHORIZE COMPLETION OF THIS ORDER.</p> <p><input type="checkbox"/> APPROVED WITH NO EXCEPTIONS MANUFACTURE ELEVATOR AS PER DRAWING</p> <p><input type="checkbox"/> CHANGE AS NOTED REAPPROVAL REQUIRED FOR REPRODUCTION OF THIS DRAWING</p> <p>DATE: _____</p> <p>CAUTION: SPACE THE DRAWING IS APPROVED. JOB CANCELLATION FEES WILL BE ASKED OF JOB PENDING</p>	<p>CLASSIFICATION: RESIDENTIAL BUILDING</p> <p>TELECAB TYPE: TYPE I, PREMIUM</p> <p>TELECAB USABLE DIM: 30" x 48" x 78"</p> <p>TELECAB CAPACITY: 500 LBS [227 KG]</p> <p>COLOR (ELECTROMETRIC CODE): <input type="checkbox"/> WHITE <input type="checkbox"/> BIRCH <input type="checkbox"/> OAK <input type="checkbox"/> SLATE</p> <p>FINISHES: <input type="checkbox"/> 216 FT/AMH <input type="checkbox"/> 14 FT/AMH <input type="checkbox"/> 3 LEVELS <input type="checkbox"/> 3 OPENINGS</p> <p>NUMBER OF OPENINGS: <input type="checkbox"/> 1 OPENING <input type="checkbox"/> 2 OPENINGS <input type="checkbox"/> 3 OPENINGS</p> <p>DRIVE SYSTEM: <input type="checkbox"/> TO 2 CHAIN HYDRAULIC <input type="checkbox"/> MANUAL</p> <p>CHG DOOR OPERATION: <input type="checkbox"/> HYDRAULIC DOOR CLOSER <input type="checkbox"/> POWER OPERATED</p> <p>PURIFIER INJECTOR: <input type="checkbox"/> 1 1/2" <input type="checkbox"/> 2"</p> <p>PLUMBING WALL THK.: FULL</p> <p>CABINET DIAMETER: <input type="checkbox"/> 2" <input type="checkbox"/> 2 1/2"</p> <p>CABINET WALL THK.: 1/4"</p> <p>CHAMBER FLOOR LENGTH: 2155 LBS [984 KG]</p> <p>WEIGHT/PLUMBING: 2155 LBS [984 KG]</p> <p>SYSTEM WALL PRESSURE: 2000 PSI</p> <p>OIL CAPACITY: <input type="checkbox"/> 1.5B GAL/US <input type="checkbox"/> 3.0B GAL/US</p> <p>MOTOR: 1.0 HP, 115 V</p> <p>CHART: 400, 575, 3</p> <p>CONTROLLER: RELAY LOGIC</p> <p>POWER OPERATION: <input type="checkbox"/> 110 VAC + 12 VDC DOWN STD <input type="checkbox"/> 12 VDC UP + DOWN <input type="checkbox"/> 220 VAC/50 HZ</p> <p>OPERATION: CONSTANT PRESSURE, AUTO-DIEP FEATURE</p> <p>HALL ENTRY: <input type="checkbox"/> SURFACE MOUNTED <input type="checkbox"/> RECESS MOUNTED</p> <p>BEARING WALL: <input type="checkbox"/> WOOD <input type="checkbox"/> CONCRETE</p> <p>FLOOR PLUG: <input type="checkbox"/> REQUIRED <input type="checkbox"/> NOT REQUIRED</p> <p>UNDER PAU: <input type="checkbox"/> REQUIRED <input type="checkbox"/> NOT REQUIRED</p> <p>FOR APPROVAL: F.B. _____ BY _____ DATE _____</p> <p>REV.: DESCRIPTION _____ BY _____ DATE _____</p> <p>CUSTOMER: _____</p> <p>PROJECT: _____</p> <p>DATE: _____</p> <p>TOLERANCES IF NOT SPECIFIED: FRACTIONS 1/16" (3)</p> <p>DESIGNER: _____</p> <p>DATE: _____</p> <p>SCALE: _____</p> <p>DATE: _____</p> <p>DESIGNER #: _____</p> <p>REV. #: 0</p> <p>TYPE I - PLAN VIEW</p>
<p>PROVIDED BY OTHERS:</p> <ol style="list-style-type: none"> 1) POWER SUPPLY: DEDICATED CIRCUIT, 120 VAC, 20 AMP, SINGLE PHASE 2) CONSTRUCTION: STEEL LOAD BEARING WALL AND FLOOR CUT OUT NEEDS TO SUPPORT THE LOADS FROM ON THE WALL TO INCLUDE TWO SETS OF THREE 2" x 4" WOOD STUDS 24" APART AS BROWN OR THE FLOOR CUT-OUT DRAWING 3) DIMENSIONS: CONSULTOR/CUSTOMER TO VERIFY ALL DIMENSIONS AND REPORT ANY DISCREPANCIES TO OUR OFFICE 4) REBARMENT: BEFORE INSTALLATION CAN BESET, PERMANENT POWER MUST BE SUPPLIED 5) A PHONE LINE TO CONTACT THE CAD PHONE <p>SAFETY FEATURES:</p> <ol style="list-style-type: none"> 1) ELEGANT MECHANICAL DOOR LOCK AND OPEN DOOR SENSOR 2) UNDER PANEL SAFETY SENSOR 3) EMERGENCY STOP AND ALARM 4) EMERGENCY BATTERY LOWERING 5) FULLY ENCLOSED DRIVE TOWER 6) PRESSURE RELIEF VALVE TO PREVENT PLATFORM OVERLOAD 7) SLACK CHAIN SAFETY DEVICE 8) TELEPHONIC IN CAB 9) HALOGEN LIGHT IN CAB 	<p style="text-align: center;">PREMIUM TELECAB (ABS PLASTIC COMPONENTS)</p>

3.3 Telecab Type I

FLOOR CUT-OUT FOR A 30" X 46", TYPE I TELECAB (TRADITIONAL OR PREMIUM)

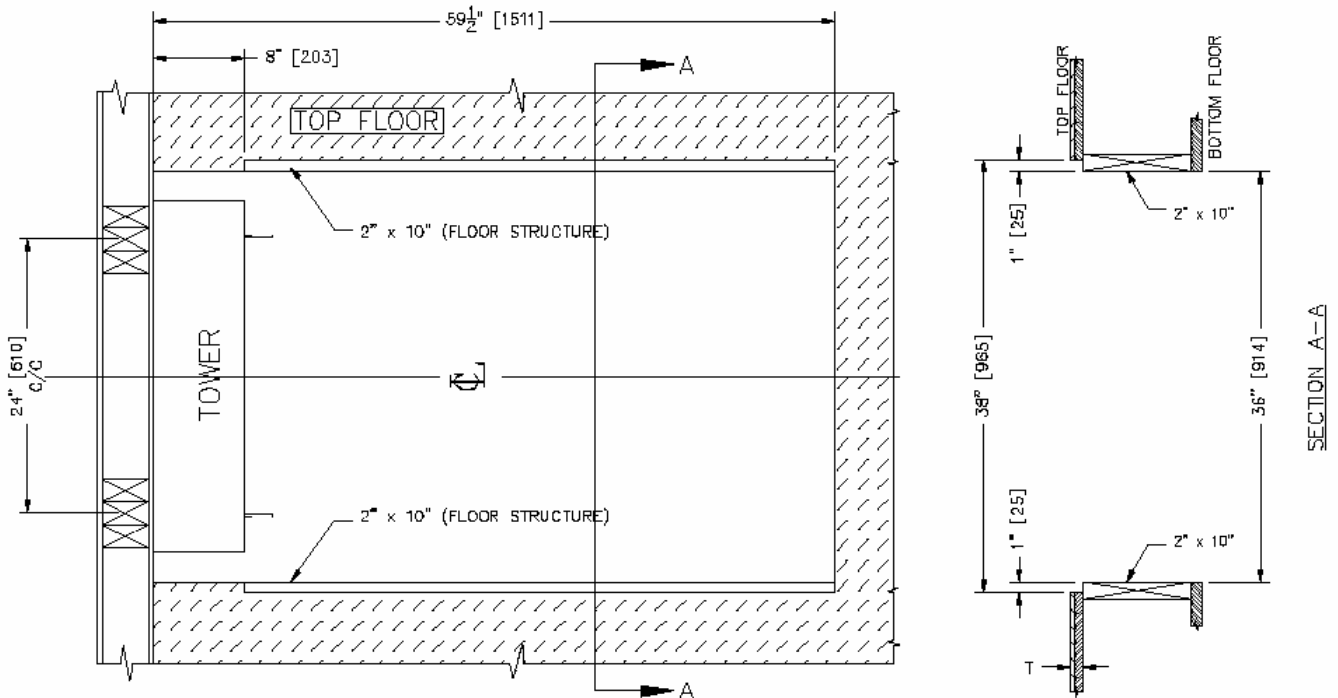

3.4 Telecab Type II

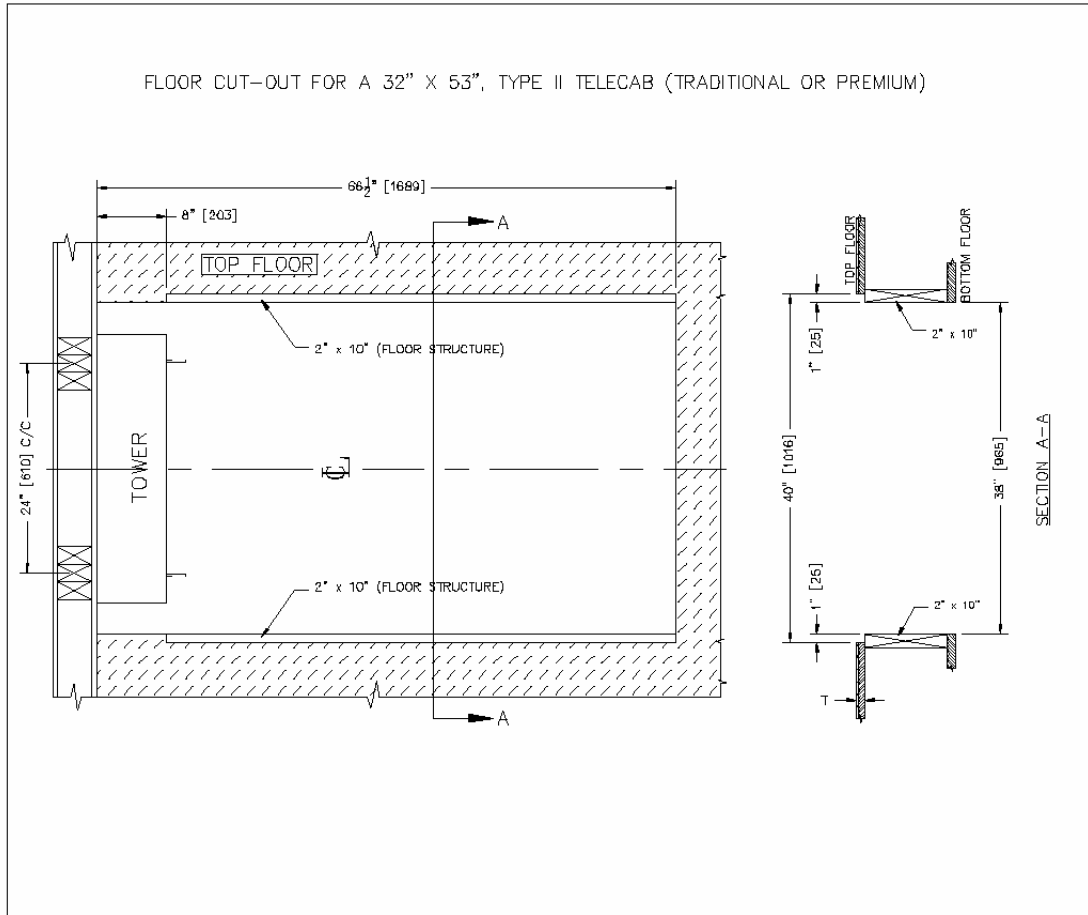

3.5 Telecab Type III one door

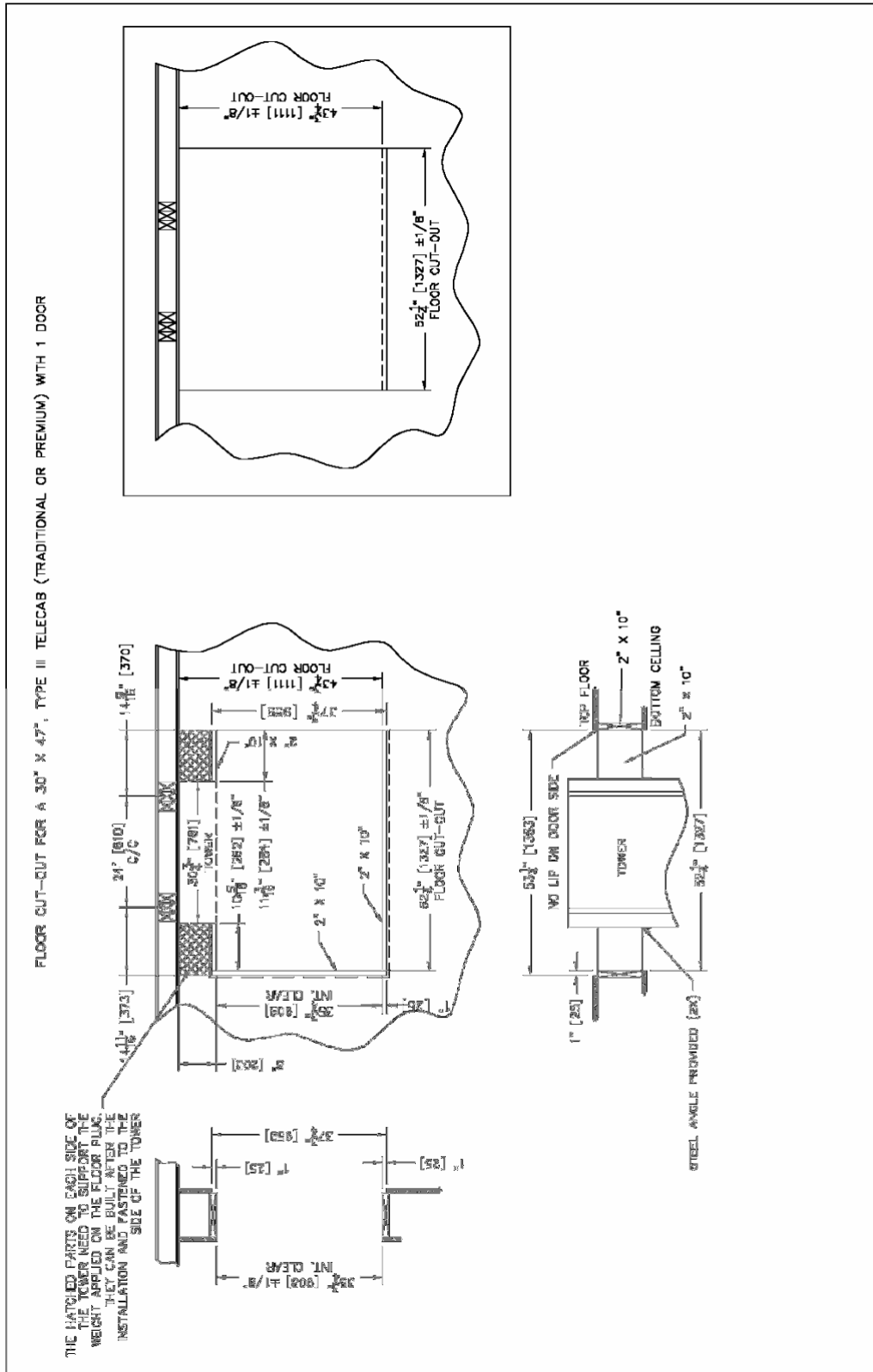

3.6 Telecab Type III two doors

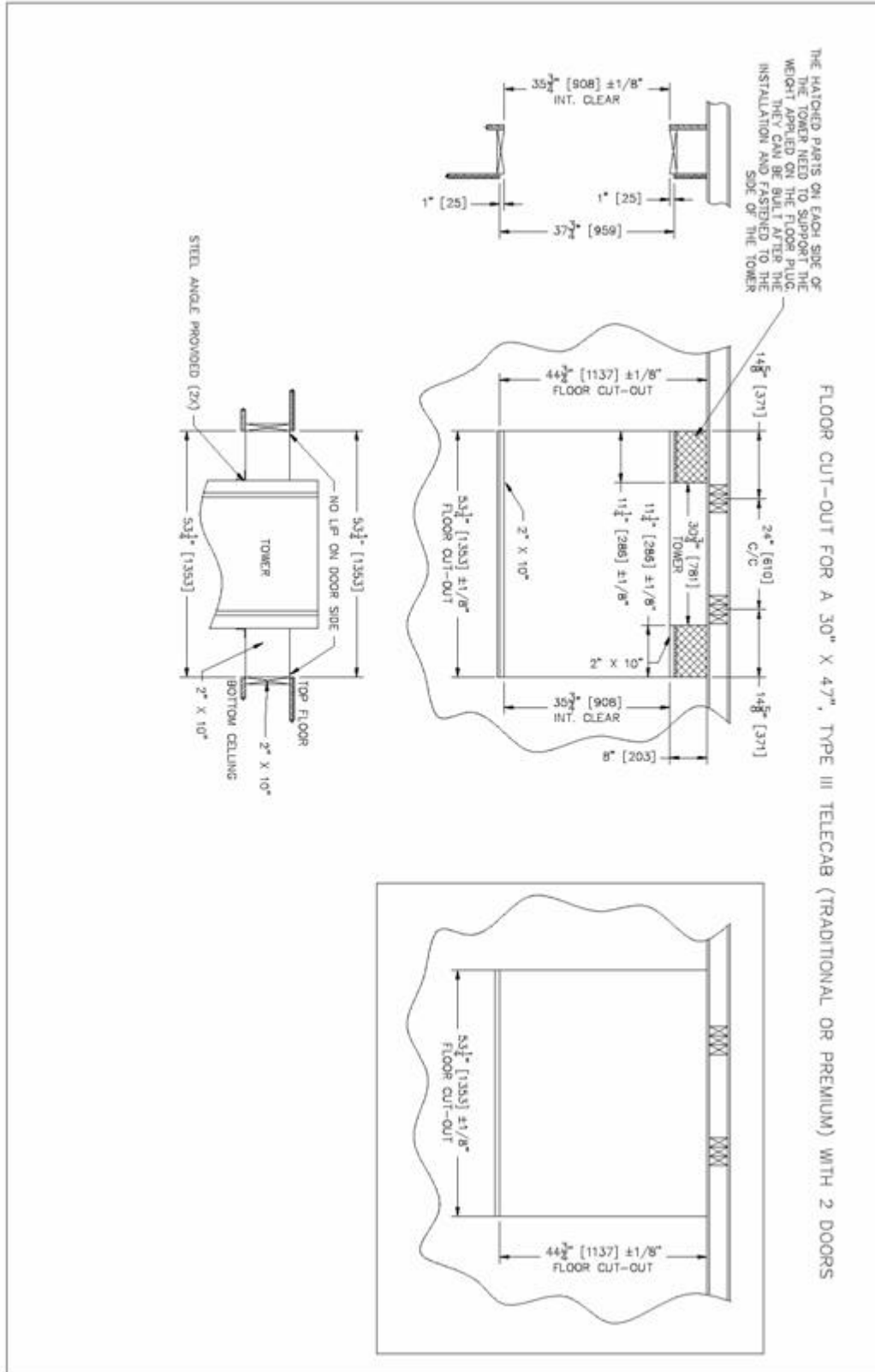

3.7 Telecab Type IV one door

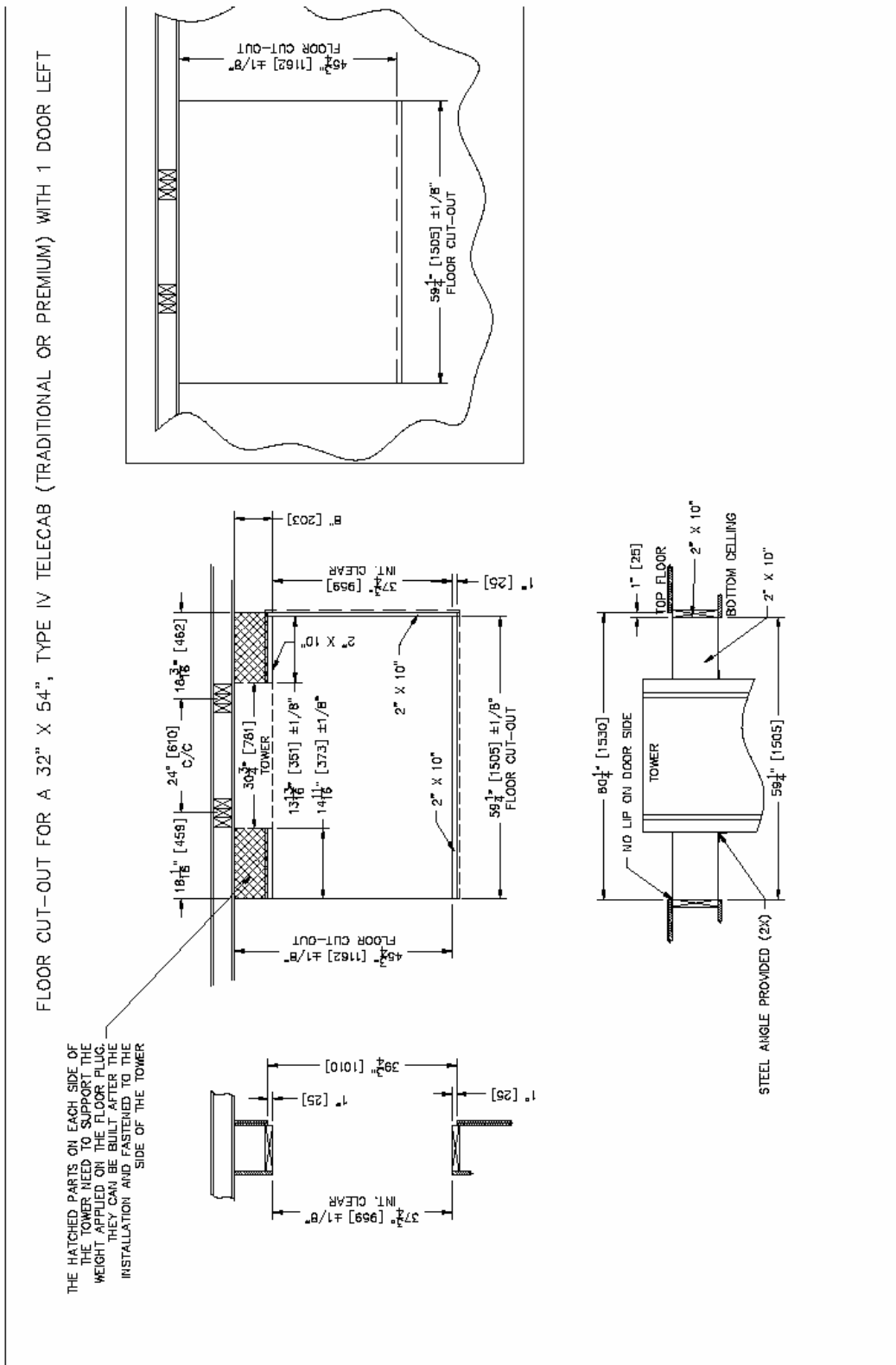

3.8 Telecab Type IV two doors

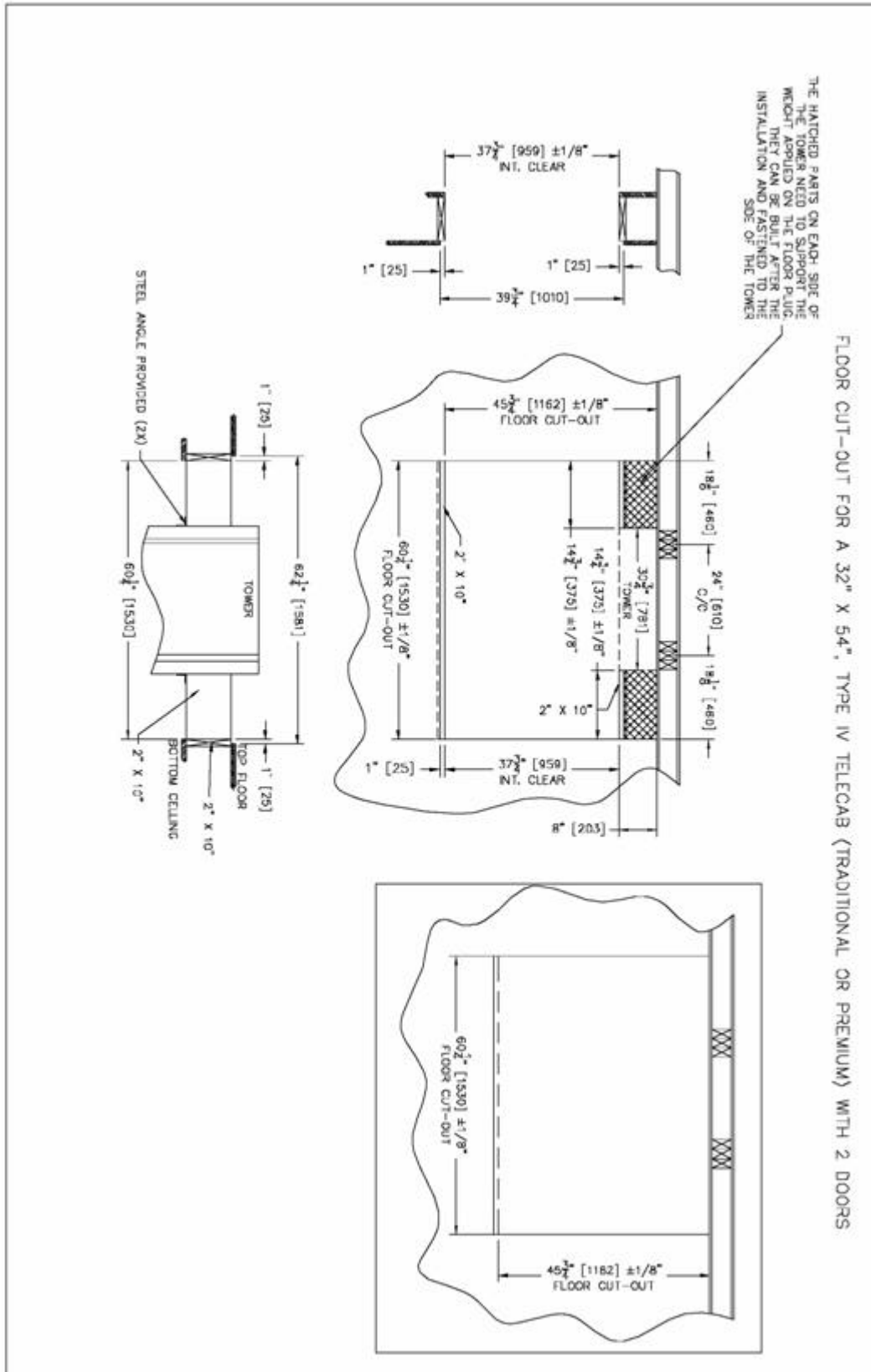

4- Architect specifications

Section 14420

Typical hydraulic residential elevator specifications

Savaria model TELECAB (No hoistway elevator)

1.0 GENERAL

1.1 DESCRIPTION

- A. Work described in this section includes providing equipment, incidental material and labor required for complete, operable hydraulic elevator installation. The elevators shall be erected, installed, adjusted, tested and placed in operation by the elevator system manufacturer or manufacturer's authorized installer.
- B. The elevator described here, manufactured by Savaria corporation inc, is a residential elevator consisting of a hydraulic tower with a lifting cab. The cab can be customized to better accommodate in a better way, the wheelchair user or a person with impaired mobility.

1.2 PREPARATORY WORK BY OTHERS

- A. The following preparatory work to receive the lifts specified in this section is part of the work by others:
1. Dedicated 110 VAC 20 amp single-phase power to operate lift to be provided. Refer to drawings for power specifications and location of junction box. Temporary power may be provided during installation of lift.
 2. No pit shall be provided.
 3. Provide a load-bearing wall to support a load of 700 lbs at any point.
 4. Provide a floor cut out. Refer to shop drawings.
 5. The floor needs to support 3000lbs.
 6. A phone line shall be provided.

1.3 QUALITY ASSURANCE

A. MANUFACTURER:

Company with not less than 22 years of experience in the design, fabrication and assembly of platforms lifts and residential elevators.

B. SUBCONTRACTOR QUALIFICATIONS:

1. Execute work of this section only by a company that has adequate product liability insurance.
2. Skilled tradesmen must be employees of the installing contractor approved by the lift manufacturer, with demonstrated ability to perform the work on a timely basis.

C. REQUIREMENTS OF REGULATORY AGENCIES:

1. Fabrication and installation work in compliance with applicable jurisdictional authorities.
2. File shop drawings and submissions with local authorities as the information is made available. Company pre-inspection and jurisdictional authority inspections and permits are to be made on timely basis as required.

D. SUBMITTALS:

Shop drawings shall show a complete layout of lifting equipment detailing dimensions and clearances as required.

The authorized distributor shall submit physical samples of all items requiring selection of color or finish.

1.4 MAINTENANCE

A. The elevator shall be cleaned regularly and inspected at intervals no longer than every 6 months.

1.5 WARRANTY

A. The manufacturer shall offer a 30-month warranty on parts.

1.6 TESTING

The Telecab shall be designed and tested in accordance with ASME A17.1 part V. The testing shall consist of loading the Telecab to rated capacity for several cycles to insure proper operation. No mechanical failures shall occur and nothing that would affect proper operation of the unit shall be detected.

2.0 PRODUCTS

2.1 RESIDENTIAL ELEVATOR

A. Basic specifications for Savaria’s Telecab residential elevator:

- 1. Rated Load.....500 lb (227 kg)
- 2. Rated Speed.....25 f.p.m. (0.07 m/s)
- 3. Cab Dimensions.....30”W x 46” L x 78”H (762 x 1,168 x 1,981 mm)
- 4. Levels Serviced.....2 or 3 (optional)
- 5. Number of Openings.....1 or 2
- 6. Car Access.....Enter/exit same side or front/rear
- 7. Max. Travel.....Up to 23’
- 8. Operations.....Constant pressure
- 9. Power Supply.....110 VAC, 20 amps, 1 Phase
- 10. Drive System.....2: 1 roller chain hydraulic
- 11. Paint.....Powder coat finish
- 12. Emergency Power.....Battery operation in down direction
- 13. Controller.....Electronic-free relay logic
- 15. Motor/Pump.....110VAC, 1.5HP/screw type
- 16. Color.....Among beige or white

2.2 CAR OPERATION

- A. Car Operating Panel shall consist of constant pressure buttons or rocker switches, emergency stop/alarm button, on/off key switch an emergency light, and a alarm button mounted on a removable steel panel.
- B. Emergency Operation — The car shall be equipped with a battery-operated light fixture, emergency battery lowering device and alarm in case of normal building supply failure. The battery shall be the rechargeable type with an automatic recharging system. A manual-lowering device shall be located in a lockable box at positioned at a designated landing.

2.3 PUMPING UNIT AND CONTROL

- A. The pumping unit and control shall be enclosed in the tower. The controller and pump unit shall be pre-wired and tested prior to shipment. The controller is to be electronic-free with relay logic operation for ease of maintenance and service. Pump unit shall incorporate the following features :
 - 1. Smooth stops at each landing shall be an inherent feature.
 - 2. Adjustable pressure relief valve.

3. Manually operable down valve to lower lift in the event of an emergency. This valve shall be activated from outside of the hoistway through a keyed box.
 4. Gate valve to isolate cylinder from pump unit.
 5. Electrical solenoid for down direction control.
 6. Emergency lowering by battery power, from the car control.
- 2.4 CYLINDER AND PLUNGER**
- A. The cylinder shall be constructed of steel pipe of sufficient thickness and suitable safety margin. The top of the cylinder shall be equipped with a cylinder head with an internal guide ring and self-adjusting packing.
 - B. The plunger shall be constructed of a steel shaft of proper diameter machined true and smooth. The plunger shall be provided with a stop electrically welded to the bottom to prevent the plunger from leaving the cylinder.
- 2.5 ROLLER-CHAINS**
- A. Two (2) No.50 roller chains with 5/8'' pitch. Minimum breaking strength 6100 lb (2772 kg) each.
- 2.6 LEVELLING DEVICE**
- A. The lift shall be provided with an anti-creep device which will maintain the carriage level within ½'' (12.7 mm) of the top landing.
 - B. All limit switches and leveling device switches shall be located in a position to be inaccessible to unauthorized persons. They shall be located behind the mast wall and be accessible through removable panels. Micro-switches shall not be used.
- 2.7 GUIDE YOKE**
- A. The 2:1 guide yoke/sprocket arrangements shall be supplied with two (2) sprockets, roller guide shoes, bearings and guards.
- 2.8 CALL STATIONS**
- A. Provide a surface-mounted K lockner Moeller box for upper and lower levels.
- 2.9 TERMINAL STOPPING DEVICES**
- A. Normal terminal stopping devices shall be provided at top and bottom of runway to stop the car positively and automatically. Limit switches shall be used not micro switches.
- 2.10 GUIDE RAILS AND BRACKETS**
- A. Steel "C" guide rails and brackets shall be used to guide the platform and sling. Guide rails shall form part of the structural integrity of the unit and be integral to the mast enclosure, ensuring stability and minimum platform deflection when loaded.
- 2.11 WIRING**
- A. All wiring and electrical connections shall comply with applicable codes. Insulated wiring shall have flame-retardant and moisture-proof outer covering and shall be run in conduit or electrical wireways if located outside the unit enclosure. Quick disconnect harnesses shall be used when possible.
- 2.12 DOOR LOCKS**
- A. The door locks shall be fire-rated electric door strike.
- 2.13 DOOR**
- A. The door shall be 78'' H x 30'' W and shall be made of steel with plexiglass insert.
- 3.0 EXECUTION**
- A. EXAMINATION: All site dimensions shall be taken to ensure that tolerances and clearances have been maintained and meet local regulations.

B. PREPARATION:

Pre-inspect the construction and service requirements for work by others. These requirements will be included in drawings, diagrams, engineering data sheets and special instructions before the work begins.

C. INSTALLATION:

1. Install all the components of the elevator system that are provided and that are required by jurisdictional authorities to license the lift.
2. Trained employees of the elevator contractor shall perform all installation work of this section.
3. Adjust elevator for proper operation and lean unit thoroughly.
4. Instruct users in operating procedures and owner's maintenance person in trouble-shooting and maintenance procedures.

END OF SECTION